

EH series

HITACHI

EH

3500ACII



DUMP TRUCK

- **Model Code** : EH3500ACII
- **Nominal Payload with Standard Equipment** : 168 tonnes (185 tons)
- **Target Gross Machine Operating Weight** : 309 000 kg
- **Engine** : Cummins QSKTA50-CE
Rated Power 1 491 kW (2 000 HP)



*Note: Photos in this brochure may include optional equipment.
They may also include custom-made options to meet specific user needs.*

Refined engineering and advanced Hitachi AC Drive system technology has created hauling capability well recognized in the surface mining industry.

The EH3500ACII continues to prove itself as an exceedingly capable and reliable solution to mine applications worldwide.



AC Drive Proven Performance & Economic Advantages

The Hitachi engineered AC drives make your hauler a more valuable asset in your mining operation. Better performance, higher availability, and significant reductions in maintenance and operating costs - result in a lower cost per tonne and a higher return on your investment.



High-Powered Engine

The Cummins QSKTA50-CE engine with 1 491 kW provides excellent reliability and low fuel consumption while meeting the emission regulation of U.S. EPA Tier 2.



Long Frame Life

A fabricated box section and rectangular frame rail construction provides superior resistance to bending and torsional loads. One-piece top and bottom flanges eliminate cross member tie-in joints and provide a larger exposed center area for access to major components.



Tough Body

The Hitachi horizontal stiffener design minimizes stress concentrations by dissipating load shocks over the entire body length. Closely spaced stiffeners provide additional protection by minimizing distances between unsupported areas.

Well Matched: EH3500ACII & Excavators

Excavator	EX2500-6		EX3600-6		EX5500-6	
	BH	LD	BH	LD	BH	LD
Bucket	*15.0 m ³	15.0 m ³	*22.0 m ³	21.0 m ³	*29.0 m ³	27.0 m ³
Passes	7	7	5	5	3 - 4	4

BH: Backhoe LD: Loading shovel *: SAE, PCSA heaped capacity

AC Drive Advantage



Hitachi AC drive technology, provides superior performance with higher top speeds, better gradeability and stronger retardation.

These features increase productivity and availability, and reduce operating and maintenance cost.

Lower maintenance costs are achieved with use of brushless motors and elimination of contactors.

The Hitachi AC motors do not have commutators, reducing costs and allowing the truck to achieve higher speeds. Less downtime and higher speeds result in more production and lower cost per tonne.

Hitachi AC drive systems power not only rigid haul trucks, but also electric train locomotives world wide.

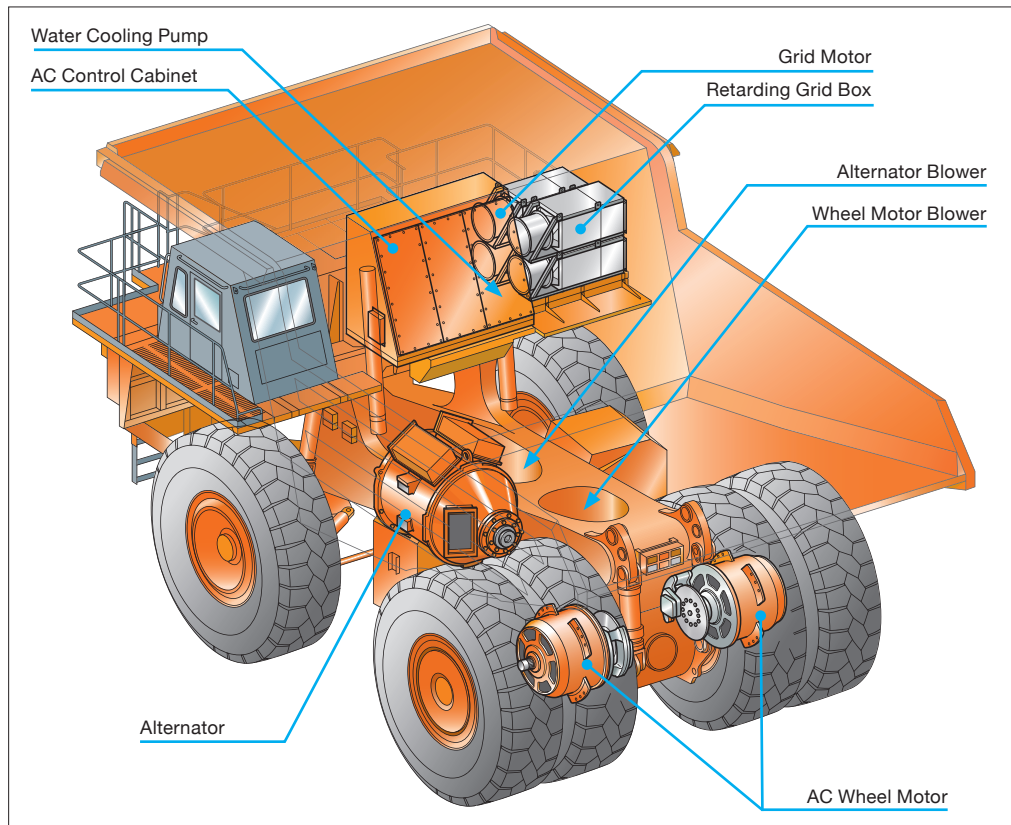

Full Retarding Capability

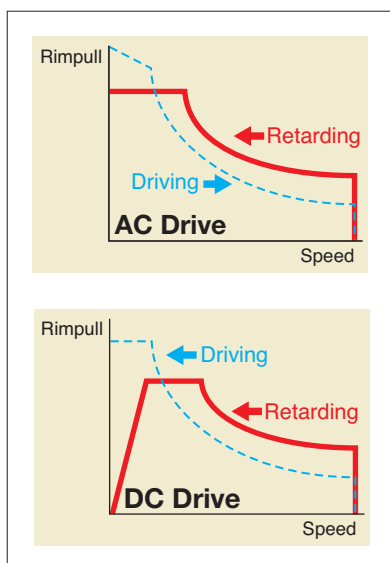

Hitachi AC drive systems provide more rimpull than a comparable DC system. Full retarding capability means the truck can be almost fully stopped without applying the service brakes.

The AC Drive Traction Motors



Hitachi's Double Path Tandem Planetary Design provides high efficiency. The 1st stationary planetary carrier and new lubricant cooling filtration system provide lower operating temperatures - longer lubricant life, better component life.

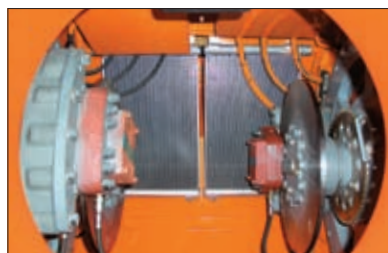

AC DRIVE CONTROL

Brake Blending, which combines service brakes with electric retarders, is applied automatically through the AC drive system to stop the hauler at speeds below 0.5 km/hr.

Therefore, the driver can usually stop the truck with the retarding pedal only, resulting in easy operation and longer service interval for the service brakes.

Auto Cruise Control keeps vehicle speed constant within the set range by limiting the minimum vehicle speed.

Auto Retarding Control keeps vehicle downhill speed constant within the set range by limiting the maximum vehicle speed.

Ease of Operation



HI-TECH ROPS/FOPS CAB

The new HI-TECH ROPS/FOPS cab has been newly equipped with a Hitachi controller and a large centrally mounted, color Liquid Crystal Display (LCD) as used in Hitachi large sized excavators. Double wall construction of 11 gauge inner and outer steel panels produces a more structurally sound cab. A three-point rubber ISO-mount arrangement minimizes vibration to the operator compartment.



Note: Shown is the machine with the door open.

Superior Suspension

The Hitachi trailing arm suspension system delivers excellent maneuverability, even at higher speeds. The trailing arm layout offers greater ease of servicing while improving truck performance compared to suspended king-pin designs. The pivot mounting of the trailing arm design allows only axial input to the strut and allows wheel movement to the vertical plane only.

Features:

- Lateral forces that act on the front wheels are minimized, resulting in reduced tire scuffing.
- Dynamic friction (side-wall force) within the strut is low due to the features of the trailing arm suspension design, allowing the use of a lighter strut engineered to a smaller diameter and longer stroke.
- The necessary frame bulk (horse-collar structure) needed to mount a suspended king-pin is non-existent.
- The elimination of the “horse-collar” member provides greater engine access.

- The NEOCON strut used with the trailing arm suspension, improves operator and component isolation, provides better hauler stability and predictable operational control.
- Locating the king-pin close to the wheel assembly and at a slight angle results in low “Dry Park Steering” effort.
- Development of the compressible media, NEOCON- E™ fluid (proprietary, silicone based, environmentally friendly) for use in the suspension strut with Helium gas, results in an improved energy absorption (isolation) system and an improved energy release (stability) system that responds favorably whether traveling empty or loaded in a wide range of ambient temperatures.

The trailing arm suspension design allows the front struts to be removed and installed without removing the front brakes or tires. This means fewer tools and less labor time are required, resulting in less downtime and higher productivity.

THE FAST FILLING SYSTEM

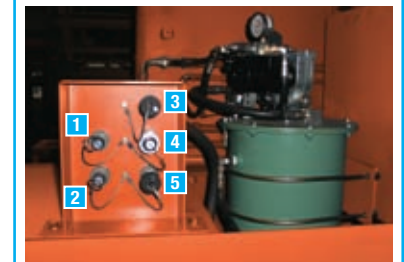
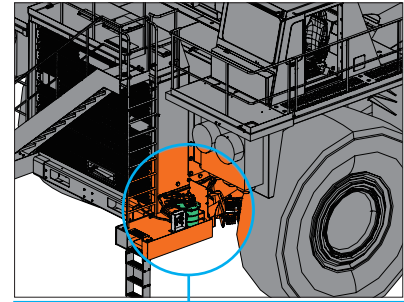

- 1. Coolant 1
- 2. Coolant 2
- 3. Grease
- 4. Hydraulic oil
- 5. Engine oil

The fast filling system, provided standard on the left side of the radiator, allows direct access at ground level for fast feeding of coolant, grease, hydraulic oil and engine oil. (Couplers are optional.)

With no horizontal deflection

Trailing Arm Suspension (Front)

NEOCON Strut (Front/Rear)

Impact

Spindle
Each controlled by a hydraulic steering cylinder, rotates around the king-pin and the outer end of the trailing arm to position the wheels for steering. The spindles are attached by one simple tie-rod.

Trailing Arm
Main suspension member to which other suspension components are attached. The trailing arms hinge on a cross tube that is clamped to the front of the frame.

Neocon Strut
The energy absorption and release component of the trailing arm suspension system. Pinned to ball bushings at the frame and at the top of each trailing arm to prevent bending movements from transferring to the strut. Receives only axial input.



SPECIFICATIONS

ENGINE

Model	Cummins QSKTA50-CE
Type	4 Cycle
Aspiration.....	Turbocharged & low temperature aftercooled
Emission Certification	U.S. EPA Tier 2
Rated Power	
SAE J1995, gross	1491 kW (2000 HP) at 1900 min ⁻¹ (rpm)
Net	1398 kW (1874 HP) at 1900 min ⁻¹ (rpm)
Maximum Torque	
(SAE J1995)	7 871N·m (802.6 kgf·m) at 1500 min ⁻¹ (rpm)
No. Cylinders	16
Bore & Stroke.....	159 x 159 mm
Displacement	50.3 L
Starting	24 Volt Electric

ELECTRICAL DRIVE

HITACHI AC-Drive System

AC Control Cabinet

Model.....	aDi800-A-00
Rectifier	Number of units..... 1
	Rated capacity
	1 340 kW
Inverter	Number of units..... 2
	Rated capacity per unit.. 800 kVA
Chopper	Number of units..... 2
	Rated capacity per unit.. 1 300 kW

Equipped with reliable water cooling system. Pressurized cabinet to reduce dust. Equipped with lockable doors for safety.

Equipped with small inverters to provide grid motors and blower motors with adequate AC current. Uniquely constructed for the Rigid Truck application.

Alternator

Model.....	YEFFC10UP-CD
Number of units	1
Capacity.....	1 500 kVA at 1 900 rpm

Equipped with an auxiliary alternator that provides AC current to grid motors, blower motors, and control cabinet coolant pump. Air cooled by AC drive blower.

AC Wheel Motor

Model.....	EFFO-KK
Number of units	2
Capacity per unit	620 kW
Air cooled by AC drive blower.	

Retarding Grid Box

Model.....	CPS-625DD
Number of modules.....	4
Capacity per unit	625 kW (3 min.)

Equipped with inverter controlled variable speed cooling fan.

Planetary Ratio	35.2
Maximum Speed	56 km/h

TIRES

Front and Rear	Rim Width
37.00R57(**) E4 Radial.....	686 mm (27 in)

Optional tires and tread patterns may be available.

Certain job conditions may require higher TKPH(TMPH) in order to maintain maximum production. Hitachi recommends evaluating the job conditions and consulting the tire manufacturer to make proper tire selection.

ELECTRICAL SYSTEM

Twenty-four volt system. 140 ampere engine driven alternator. Four 12-volt, heavy duty batteries connected in series/parallel

BODY CAPACITIES

Struck (SAE).....	74 m ³
Heap 3:1	99 m ³
Heap 2:1 (SAE).....	111 m ³

Body capacity and payload subject to change based on customer specific material density and application.

STEERING SYSTEM

Closed-center, full-time hydrostatic power steering system using two double-acting cylinders, pressure-limit with unload piston pump, and brake actuation/steering system reservoir. Accumulator provides supplementary steering in accordance with ISO 5010 and SAE J1511. Tilt/telescopic steering wheel with 35 deg. of tilt and 57.2 mm telescopic travel is standard.

Turning Diameter (SAE)	27.3 m
------------------------------	--------

HYDRAULIC SYSTEM

Two (2) Hitachi three-stage, double-acting cylinders, with electronic controlled cushioning in retraction and extension, containing dual rod seals and urethane energized scrapers, inverted and outboard mounted. A tandem piston pump combines with four position electronic pilot controlled hoist valve. The electrical controller is mounted to the operator's seat.

Body Raise Travel.....	59 degrees
Body Raise Time	17.5 s at 1900 min ⁻¹ (rpm)
Body Down Time (Float)	13.0 s

BRAKE SYSTEM

Brake systems complies with ISO 3450 (SAE J1473).

Service

An all-hydraulic actuated service braking system provides precise braking control and quick system response. The system is pressure proportioned, front to rear, for improved slippery road control.

Front Axle – Dry Disc

Disc Diameter Each (2 discs/axle, 3 calipers/disc).....	121.7 cm
---	----------

Rear Axle – Dry Disc

Disc Diameter Each (2 discs/axle, 3 calipers/disc).....	109 cm
---	--------

Secondary

Dual independent hydraulic circuits within the service brake system provide fully modulated reserve braking capability. Both front and rear dry disc are automatically applied when loss of pressure is detected.

Parking

Two spring on, hydraulic off armature disc brake heads provide effective parking. The braking system complies with ISO 3450 (SAE J1473).

Retarder

Superior retardation to zero speed on grades is achieved through AC wheel motors in conjunction with four Hitachi resistor grid packages. Service brake blending occurs at speeds below 0.5 km/h.

Maximum dynamic retarding	
Standard.....	2 800 kW

Load/Dump Brake Apply

Through activation of a switch by the operator, a solenoid is energized, sending full brake pressure to apply the rear Dry Disc brakes. For use during the load and dump cycles.

WEIGHTS (Approximate)

Net machine weight stated below includes standard equipment.
Net machine weight changes will directly affect the Nominal Payload.

Chassis with Hoist.....	114 250 kg
Body	26 750 kg
Net Machine Weight.....	141 000 kg

The Net Machine Weight specification includes operator and 100 % fuel.

Nominal Payload	168 tonnes
Target GMOW	309 000 kg
Axle Weights	

Front Axle, Empty (48%).....	67 700 kg
Rear Axle, Empty (52%).....	73 300 kg
Front Axle, Loaded (31%).....	95 790 kg
Rear Axle, Loaded (69%).....	213 210 kg



HI-TECH ROPS/FOPS CAB

New HI-TECH ROPS/FOPS Cab

ROPS complies with ISO3471 and SAE J1040-May 94, FOPS complies with ISO3449. A three-point rubber ISO-mount arrangement minimizes vibration to the operator compartment.

Comfort and Ease of Operation

New wrap-around style dashboard means controls are within easy reach and visual contact. A full complement of easy-to-read automobile type color LCD monitor and warning system, a spacious environment, six-way adjustable operator's air seat, tilt/telescopic steering wheel, filtered adjustable air vents, all contribute to operator safety and comfort.

Monitoring System

A new Hitachi system monitor and diagnoses all onboard controls including the Hitachi drive system and engine. Data links offer complete integration, while a single color Liquid Crystal Display (LCD) clearly details machine functions. Downtime is minimized with faster and more reliable troubleshooting and analysis. A new Hitachi load monitoring system offers benefits such as better equipment utilization on the jobsite, accurate unit and fleet production results, and benchmark unit statistics against fleet results. Cycle time, distance and cycle count can all be measured and recorded to further improvement of job productivity. The Hitachi load monitoring system is fully integrated with the Hitachi vehicle monitoring system and display interface, avoiding potential failure or error common in aftermarket systems.

Display
Display Control Panel

1. Speedometer with odometer
2. Tachometer with shift lever indicator
3. Engine oil pressure
4. Engine coolant temperature
5. Travel motor temperature
6. Steer / brake supply pressure
7. Load weight indicator
8. Fuel gauge
9. Central warning
10. Engine indicators
11. Travel device indicators
12. Hydraulic / lubricant indicators
13. Pilot indicators

Excellent Serviceability

A removable front cover of the cab allows easy access to the service brake valve and heater connections. A removable cover located behind the seat provides easy access to the electric components, Hitachi controller, and all electrical junction points.

SUSPENSION

Front Suspension

Independent trailing arm for each front wheel. NEOCON struts containing energy-absorbing gas and compressible NEOCON-E™ fluid are mounted between the trailing arms and frame. Variable damping and rebound features are included.

Rear Suspension

"A" frame structure, integral with axle housing, links drive axle to frame at a forward center point with a pin and spherical bushing. A track rod provides lateral stability between the frame and drive axle. Heavy-duty rear-mounted NEOCON struts containing energy-absorbing gas and compressible NEOCON-E™ fluid suspend the drive axle from the frame. An integral rebound feature is included.

SPECIFICATIONS

FRAME

Full fabricated box section main rails with section height tapered from rear to front. Narrow at the rear to support the load and wider at the front allowing truck stability and excellent engine access for servicing. One piece top and bottom flanges that eliminate cross member tie in joints and provide a large exposed center area for access to major components. Large radii at frame junctions are blended and ground to minimize stress concentrations. Weld joints are oriented longitudinally to the principal flow of stress for greater durability and more strength.



BODY

An extended canopy protects the service deck area. High tensile strength 400 BHN abrasion resistant alloy steel is used in thicknesses indicated below:

Floor.....	19 mm
Front.....	10 mm
Sides.....	10 mm
Canopy.....	6 mm
Corners.....	12 mm

High strength 690 N/mm² (100 000 psi) alloy steel is also used for the canopy side members and floor stiffeners. The body is rubber cushioned on the frame.

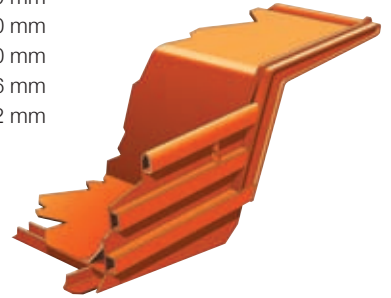

Optional Body Liners

Floor & Corners.....	12 mm
Sides & Front.....	6 mm
Canopy.....	6 mm

Special plate thicknesses and partial plates are available.

SERVICE CAPACITIES

Main Accumulator.....	70 L
Crankcase (includes filters).....	200 L
Cooling System.....	531 L
Fuel Tank.....	2 950 L
Hydraulic System.....	789 L
Planetary Drives (L&R).....	210 L
Front Wheels (L&R).....	17 L
Windshield Washer.....	20 L

PERIMETER VISIBILITY

The addition of mirrors and cameras to the base model make the truck compliant to the perimeter viewing requirement of standards ISO 5006 and ISO 14401.



Front view mirror (LHS)



Side view mirrors (LHS)



Camera monitor

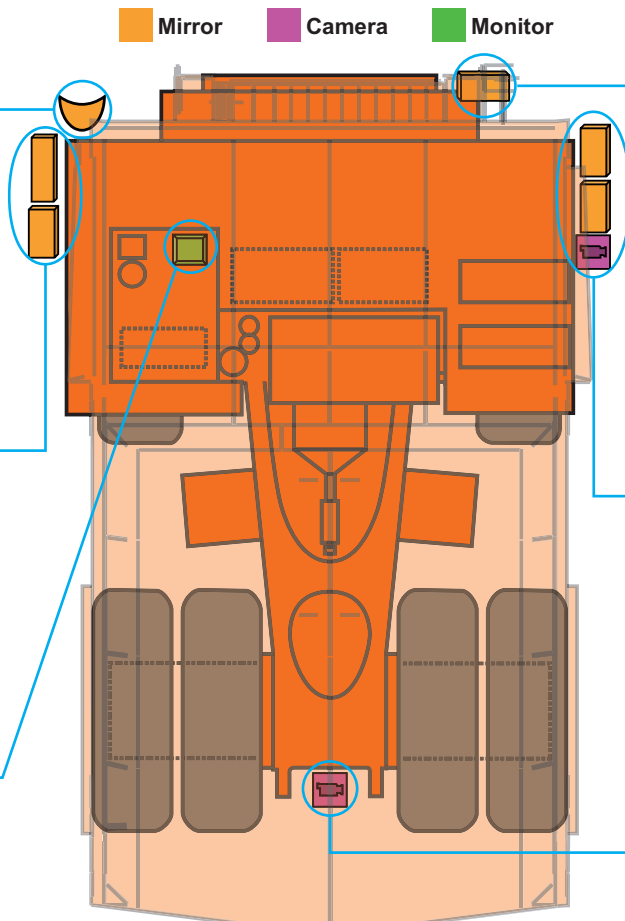

Front view mirror (RHS)

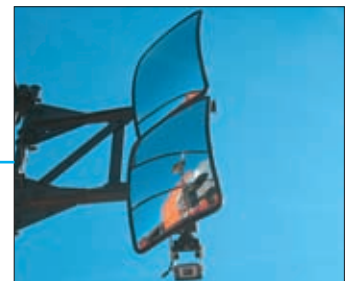

Side view mirror and camera (RHS)

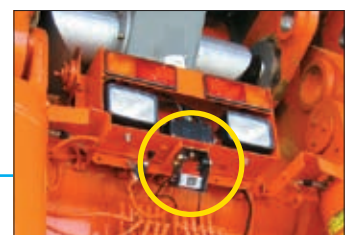

Rear view camera

EQUIPMENT

STANDARD EQUIPMENT

GENERAL

AC drive system	Fuel/Water separator
Auto cruise control	IGBT controlled blower fan motors (2)
Auto retarding control	IGBT controlled grid fan motors (4)
Brake blending control	Load weighing system
Control cabinet liquid cooled/lockable	NEOCON suspension struts
Automatic lubrication system (Lincoln)	Operator arm and grid box guards
Battery isolation switch	Rear view camera
Body prop pins	Rear view mirrors (4)
Deck mounted muffler	Rims, available for 37.00R57 & 42/90R57 tires
Diagonal front stairway	Side view camera (RHS)
Electric controlled hoist system	Suction port shut off valve at hydraulic tank
Electric horns	Supplementary braking system, accumulators
Engine access steps (2)	Supplementary steering system, accumulators
Engine shutdown switch	Tire guards
Beside engine (2)	Tow hooks, front
Ground level	Tow lugs, rear
Inside rear axle	
Fast fluid filling system provision	
Fast fuel filling system provision	
Front view mirror, LHS/RHS	

CAB

Air conditioner	LCD system monitor
Air suspension seat for operator, 6 position	Load and dump switch
AM-FM radio	Seat belts, retractable (for operator/trainer)
Auxiliary outlet, 12 volt	Tinted safety glass, with roll-down windows
Camera monitor	Trainer's seat
Engine shutdown switch	12 volt accessory connection
Heater and defroster	
Integral ROPS/FOPS cab	

INDICATORS AND GAUGES SHOWN ON MONITOR DISPLAY

Brake/steering hydraulic oil pressure gauge	HCM code
Central warning indicator	Message
Clock	SAE code
Coolant temperature gauge	Light indicators
Drive related warning indicator	Load meter
Engine oil pressure gauge	Shift lever position indicator
Engine related warning indicators	Speedometer with odometer
Engine stop warning indicator	Stop valve warning indicator
Fuel gauge	Tachometer
Hour meter	Turn signal indicator
Hydraulic related warning indicators	Wheel motor temperature gauge

MACHINE LIGHTS

Backup lights (2)	Halogen headlights (8)
Clearance lights (4)	Ladder light
Deck lights (2)	Rear axle compartment light
Engine compartment lights (2)	

OPTIONAL EQUIPMENT

Auxiliary dump connection	Continuous heated body
Auxiliary steer connection	Fast fluid filling system couplers
Body liners (400BHN)	Fast fuel filling system coupler
Body prop cable	Halogen front tire lights (2)
Body sizes **	Heated mirrors
Cold weather package	HID headlights (4) or (8)
Extreme cold weather package includes Kim Hot coolant and oil pan heater, and a fan clutch	Loadweight displays
Mild cold weather package includes Kim Hot coolant and oil pan heater	Spare rim
	Trolley assist configuration **
	Under view mirror

** : engineered on request

OPTIONAL EQUIPMENT WEIGHT

Body liners (400BHN) plates including floor & corners (12 mm thicknesses), sides & front and canopy (6 mm thicknesses)6 870 kg



DIMENSIONS

Unit: mm

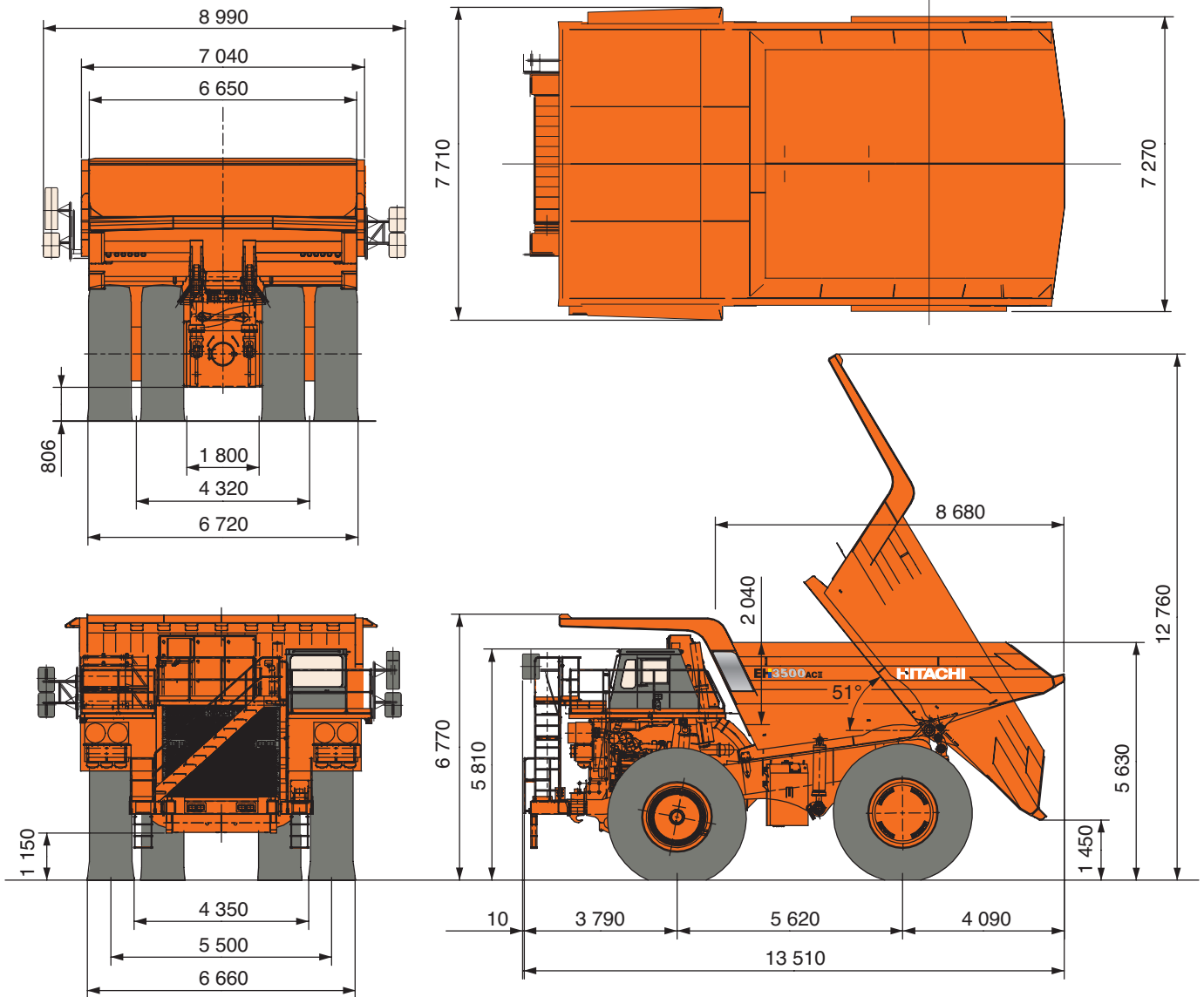

NOTES:

Dimensions shown are for an empty machine with 37.00R57 tires.

These specifications are subject to change without notice. Illustrations and photos show standard models, and may or may not include optional equipment, accessories, and all standard equipment with some differences in color and features. Before use, please read and understand the Operator's Manual for proper operation.

