

Sandvik DC120

Surface Top Hammer Drills



Sandvik DC120 is a hydraulic, self-propelled drilling unit on a 4-wheel drive carrier.

Typical applications for DC120 are foundation drilling, road cutting, trenching, bolting, line drilling in dimensional stone quarries and other special drilling applications. Therefore DC120 is most often used by construction contractors, mines and quarries, and the municipal sector. Thanks to its versatility DC120 is often included in the equipment fleet of rental houses as well.

Hole Diameter:	22 - 45 mm ($\frac{7}{8}$ " - $1\frac{3}{4}$ ")
Rock Tools:	19, 22 or 25 mm ($\frac{3}{4}$ ", $\frac{7}{8}$ " or 1") rods
Rock Drill:	5,5 kW
Engine Output:	37 kW
Flushing Air:	1,2 m ³ /min, up to 8 bar
Production Capacity:	300 - 540 m ³ /8h
Total Weight	2 710 kg

HYDRAULIC ROCK DRILL

Rock drill type	HEX I
Drill rod diameters	HEX 19 x 108 mm; HEX 22 x 108 mm; HEX 25 x 108 mm
Operating pressure	100 - 160 bar
Percussion rate	82 Hz
Percussion output power	5,5 kW
Maximum rotation torque	100 Nm/120 bar
Shank lubrication	Air / oil mist
Flushing	Air
Weight	46 kg

FEED

Chain feed type	CF 100 x 32 / HEX I
Length of feed	4 540 mm
Rock drill travel	3 300 mm
Max. length of starter rod	3 200 mm hexagonal or 10', R23 MF
Hole depth with starter rod	2 800 mm (9' 2")
Max. length of two rods	6 400 mm (21')
Hole depth with second rod	6 000 mm (19' 8")
Feed/pull out force	3.7 kN
Front centralizer	Manual
Travelling centralizer	Manual
Feed extension travel	600 mm (2')
Feed swing	+/- 47°
Feed tilt	110°
Weight without steels	155 kg

BOOM

Boom type	DB 120, articulated
Boom length	3.8 m
Boom swing	+/- 43°
Drilling coverage on flat	10 m ²
Collaring height	+2.2 m/-4.0 m
Horizontal holes	Sideways, forwards

HYDRAULIC SYSTEM

Hydraulic system type	Open center, direct control
Filtration rate	10 micron abs.
Cooling capacity	up to +50°C ambient
Hydraulic oil tank	45 l
Shank lubrication device	WL 30

POWERPACK

Engine type	CAT C 2.2, water cooled
Number of cylinders	4
Engine output	37 kW / 2 800 rpm
Transmission type	Direct/polygroove belt
Hydraulic pumps	Three gear pumps
Screw compressor type	Enduro 3
Air flushing capacity	1.2 m ³ /min
Flushing air pressure	4 - 8 bar
Air cleaner	2 pcs
Fuel tank	75 l
Average fuel consumption	4 - 6 l/h
Max. operating altitude	3 000 m

CONTROL SYSTEM

Tamrock TA 132 / 120	Direct hydraulic
Antijamming system	Hydraulic, stepless
Voltage	24 VDC
Boom and drilling control	Direct hydraulic
Driving and jack control	Direct hydraulic

DUST COLLECTOR

Dust collector type	DC 120
Capacity/vacuum	5 m ³ /min at 855 mm vacuum H ₂ O
Filter elements/material	6 pcs/fiber
Total filter surface	4.8 m ²
Weight	90 kg

CARRIER

Carrier type	Rubber tyred, 4-wheel drive
Ground clearance	300 mm
Tramming force	20 kN
Tramming speed	3.6 km/h
Number of hydraulic jacks	4

STANDARD COMPONENTS

Rock drill	HEX I, hydraulic
Chain feed	CF 100 x 32 / HEX I, incl. one set of jaws
Rod rack	On the carrier
Boom	DB 120, articulated
Carrier	Rubber-tyred
Powerpack	Diesel driven, hydraulic pumps and on-board compressor
Hydraulic system	Open center
Control system	TA 132/120, manual
Dust collector system	DC 120, hydraulic
Working lights	4 pcs
Hydraulic jacks	4 pcs
Manuals	1 x paper copy 1 x CD-ROM (ToolMan)

THE JAWS FOR DRILL STEELS

Drill steel type	Drill steel diameter	Recommended hole diameter
Hexagonal steels	19 mm $\frac{3}{4}$ "	22 - 27 mm $\frac{7}{8}$ " - $1\frac{1}{16}$ "
Hexagonal steels	22 mm $\frac{7}{8}$ "	28 - 45 mm $1\frac{7}{64}$ " - $1\frac{3}{4}$ "
Hexagonal steels	25 mm 1"	35 - 45 mm $1\frac{3}{8}$ " - $1\frac{3}{4}$ "
MF rods	R23	33 - 45 mm $1\frac{5}{16}$ " - $1\frac{3}{4}$ "
Shank adapter/ Shank rod	R23	33 - 45 mm $1\frac{5}{16}$ " - $1\frac{3}{4}$ "
Shank rod Alpha 250	25 mm 1"	35 - 45 mm $1\frac{3}{8}$ " - $1\frac{3}{4}$ "

If several jaws selected please specify jaws assembled

SELECTION OF OPTIONS

1.	Spirit level angle indicator
2.	TIM 1402 feed angle measuring system for DC120
3.	TIM 1403 feed angle and depth measuring system for DC120
4.	Shut down of suction for water holes
5.	Water flushing kit without water pump
6.	Chain tracks
7.	Hydraulic winch
8.	Electric heater for engine
9.	Manual fuel filling pump
10	Electric fuel filling pump
11	Grinder Dynaset

12.	Grinder Sandvik RGI00H
13.	Central lubrication system Lincoln
14.	Exhaust gas purifier
15.	Biodegradable hydraulic oil, Shell Naturelle HFE 46 or HFE 68
16.	Kit for alternative steels, each
17.	First service kit for DC120
18.	Special tools for HEX I
19.	Security+ (Silver, Gold or Platinum)
20.	Extra manuals, price will be added according to pricing sheet

COVERAGE AREA

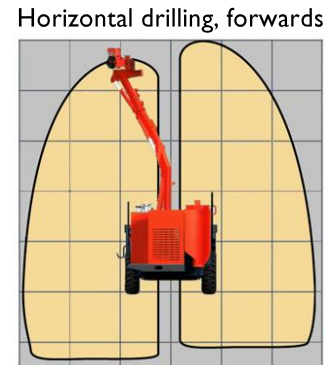
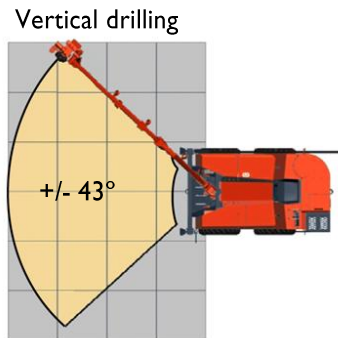
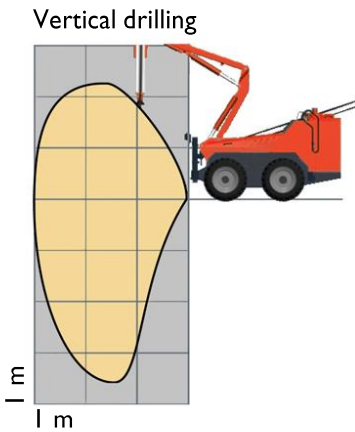

Horizontal drilling, sideways
 With manual roll-over

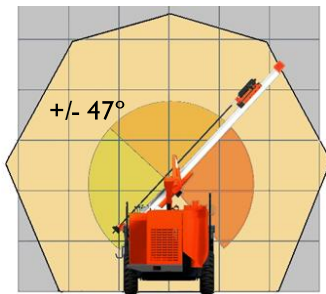

Horizontal drilling, sideways

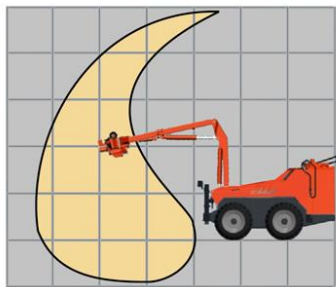

TRAMMING AND TRANSPORT DIMENSIS

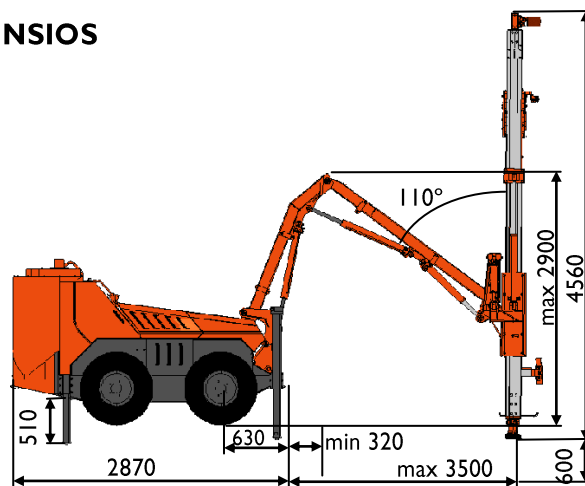
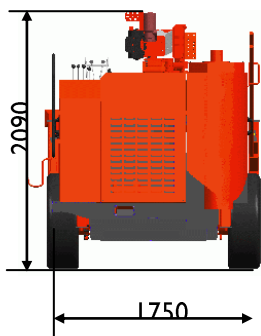

Weight (without options)	2 710 kg
Width	1.8 m
Height	2.2 m
Total length	4.5 m